

PROGRAMMING AND INSTALLATION
MANUAL

Keypad LCD-L

(software version 3.10)

CA-10 plus

Satel[®] 

GDAŃSK





WARNING

Due to safety reasons, alarm system should be installed by qualified personnel only.

Because alarm system may contain hazardous items, its components should be kept out of reach of unqualified personnel.

In order to avoid the risk of electric shock, read carefully this manual before proceeding to installation. Any connections should be made in deenergized state only (i.e. with power supply disconnected).

Making any construction changes or unauthorized repairs is prohibited. This applies, in particular, to modification of assemblies and components.

The SATEL Company recommends that operation of the whole alarm system be regularly tested. However, a reliable alarm system does not prevent burglary, assault or fire from happening, it only diminishes the risk that such a situation will cause no alarm or notification.

CA10 plus LCD-L Keypad v3.10

The keypad designated with the symbol LCD-L is a new design version, having reduced dimensions of housing and display, of the hitherto manufactured LCD keypad. Its operation is based on the identical program as the above mentioned LCD keypad.

LCD keypad with firmware version 3.10 is compatible with CA10plus alarm panel with firmware version 4.7. It's also backwards compatible with CA10plus alarm panels (firmware version 3.0 or newer).

The LCD keypad is designed to control the Satel CA10 plus alarm panel. It supports everyday use as well as programming the panel. Easily readable liquid crystal alphanumeric display provides accurate information on the system status or the currently performed user operation and thus helps avoid errors. While programming the panel required functions can just be selected from the displayed list.

The panel has its own processor which controls the user-panel communication. It analyses data from the entire alarm system and thus the keypad can simultaneously display the status of all partitions.

The keypad design with software in the version **3.00** (or newer) has been changed as compared with the previous version (2.04). The keypad address jumpers, as well as the jumpers described as T and L, have been removed and replaced with an optional software setup of the corresponding parameters (see details in the section „LCD Keypad Installation“).

Panel CA10 plus with LCD-L keypad acquires new features:

- System status messages displayed in text format provide easy readable information on essential events.
- Zone descriptions defined by the installer help to determine the alarm cause.
- Visible system clock and date help to ensure error free function of the panel.
- LCD keypad can display the status of all 16 zones, which helps in controlling large alarm systems.
- Partition names help to control multipartition systems with a single keypad.
- While reviewing the event log, descriptions of events and occurrence times are displayed in text format.
- User functions can be accessed by selecting them from an appropriate choice list.
- Service programming is easier.

The complete set of keypad functions is available when it is connected to the panel CA10 of version v3.0 (or newer) designed for LCD keypads.

All service functions of CA 10plus with firmware version 4.7 are available with use of LED keypad, LCD keypad (firmware version 3.10 or later) and with use of computer running Dload10 software in version 1.00.14 (or later).

Keypad description.

The keypad displays information on a 2-line LCD display (2x16 characters) with backlight and six additional LED controls.

LED controls' functions:

- **alarm** - signals occurrences of alarms.
- **trouble** - blinks when the panel signals a hardware problem or telephone communication trouble.
- **armed: A B C D** - partition status signaling:
 - blinking (while the **alarm** control is off) signals exit delay running,
 - control stays on when the partition is armed.

The LEDs marked with letters A B C D correspond to numerical denotation of partitions available in the system:

- LED A – partition 1
- LED B – partition 2
- LED C – partition 3
- LED D – partition 4

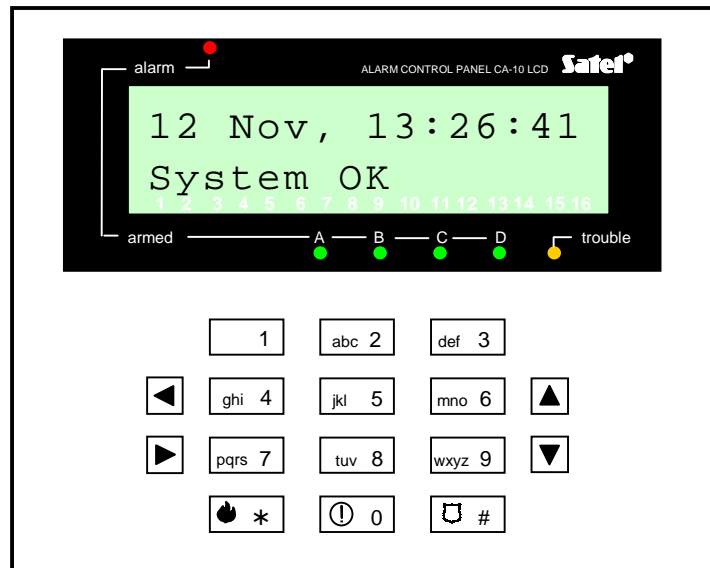

Figure 1. View of LCD-L keypad.

The function of LED controls changes after user or service mode is entered, according to the principles of status communicating by LED keypads (c.f. "CA10 plus with LED keypad user manual").

The keypad has 12 keys, labeled according to telephone data input standard. Additional four arrow keys support MENU navigation and selecting functions. After a function has been chosen, the arrow keys support programming. The keys ◀ and ▶ move the cursor, the key ▲ backspaces deleting the character that proceeds the cursor and the key ▼ toggles the data input mode (insert or overwrite).

Modes.

The keypad can function in one of the following three modes:

1. **Text mode:** the first line displays system date and time. The second line displays system status messages, which can be standard (e.g. SYSTEM OK, ARMED etc.), or defined by the installer (e.g. SERVICE 505-34-77 instead of SYSTEM TROUBLE). In this mode it is possible display all current messages alternately or according to priority. In priority mode only the highest priority message is displayed (e.g. ALARM). In non-priority mode all relevant messages are displayed one after another in a closed cycle (e.g. ALARM and ARMED by turns).
2. **Mixed mode, LCD standard:** the first line displays system date and time while in the second line the status of all 16 zones is being monitored. The status of each zone is displayed as a single character (e.g. * = zone OK, N = zone violated). After a change in the system status (e.g. after arming the system) the keypad displays the status as in the first mode and after a while turns to zone monitoring.
3. **Mixed mode, LED standard:** this mode is similar to the second one. The second line is used to monitor the status of 12 zones as in the case of LED keypad.

Operating mode 1 or 2 is recommended for the LCD-L keypad. The user can temporarily change the display mode, switching over between the text mode and the zone state display by holding down the ▼ key.

LCD-L keypad installation

The keypad is designed to operate indoors in normal humidity. It should be mounted straight on a flat surface.

Attention: The LCD display is fragile. It can be damaged when dropped.

Connecting the keypad.

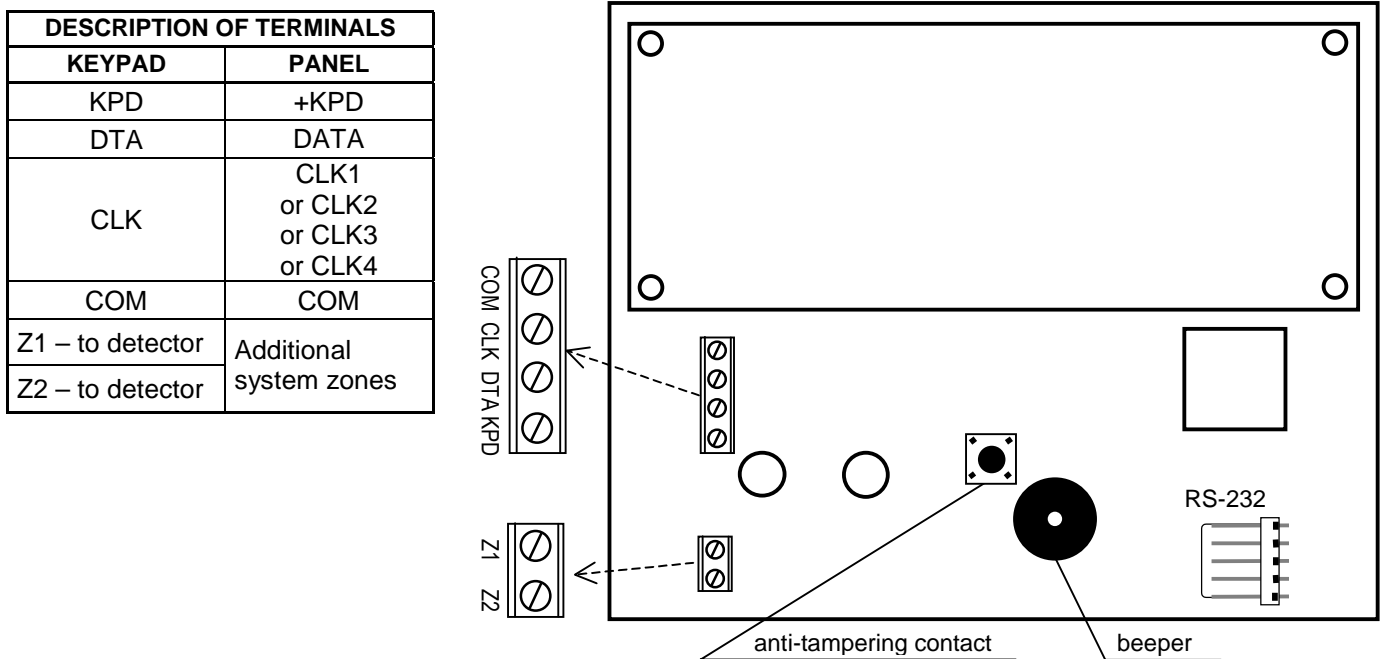

Figure 2. Schematic view of the keypad board including designations of wire terminals (version LCD-L V1.2).

The connections are made as in the case of LED keypad. The panel can operate both with LCD and LED keypads in any configuration. The only limitation is that parallel connecting any LCD keypads to the same CLK panel port is not allowed.

Only zone expanders with version 2 are allowed (label dated February 1998 or later). Since LCD keypads take larger current than LED keypads (especially when back-lighting is on), wire resistance must be taken into account in the case of supply and earth cables.

The LED keypad address setting jumpers (DCBA) have been replaced in the version 3.00 with a parameter programmed by means of the service function of the LCD-L keypad. The keypad address can be changed in two ways:

1. Directly (skipping the service code):

- Disconnect the keypad power supply and the data bus wires (CLK, DATA).
- Short-circuit the CLK and DATA terminals of the keypad.
- Switch on the keypad power supply. The following text will be displayed: „Keypad hardware address: 1001” (the default value, corresponding to the jumpers read out in the ABCD sequence).

- Using the [0] and [1] keys, enter the proper address and then press the [#] key. The „Address set” text will be displayed on the keypad.
- Connect the keypad to the control panel in appropriate way (CLK, DATA).

NOTE: For correct handling of the LCD-L keypads by the CA-10 plus control panel, the FS-124 function must be performed on each of the LCD-L keypads connected to the panel.

2. By means of the keypad service functions:

- Activate the control panel service mode [SERVICE CODE][#].
- Select in turn the items in menu of displayed functions: → LCD keypad; →Settings; →Keypad address.
- Using the [0] and [1]keys, enter the proper address and then press the [#] key. The keypad will display the text:
„Set addresses (FS 124) ? 1=Yes”.
- Press the [1] key to automatically perform the FS-124 service function and save the settings.

The functions of the other keypad jumpers have been replaced by the options available in the submenu of the LCD-L keypad service functions (→LCD keypad; →Settings; →Options). These options have the following descriptions:

- Long illumination (T jumper function) – if not selected, the option will set the 40s time, and when selected, it will set the 150s time of waiting for no key depressed (e.g. when reviewing the zones state after holding down the ▼ key, the review will be ended by the keypad after the time set with this option if no key is pressed).
- Permanent illumination (L jumper function) – if selected, this option will cause a permanent backlighting of the keypad and a dim permanent backlighting of the display, irrespective of the keypad settings indicated in the service mode.

As the LCD-L keypad consumes more power than the LED keypads (especially when the illumination of keypad and display is on), it is important that resistance of the power cables and grounding conductors be taken into account when planning the cable layout.

In the case of standard 8x0.5 cable to ensure proper keypad function the following number of wires versus the panel-keypad distance should be used.

Distance	Connection	Number of wires
up to 50 m	KPD and COM	2 x 1
	CLK and DTA signals	2 x 1
up to 100 m	KPD and COM	2 x 2
	CLK and DTA signals	2 x 1
up to 200 m	KPD and COM	2 x 4
	CLK and DTA signals	2 x 1

Note: the keypad power supply voltage (measured between "KPD" and "COM" on the keypad side) must not drop below 11V when the back-lighting is on.

After the control panel power up, the keypad can display message "Change panel's EPROM or set the correct keypad address". This is usually because the keypad address is different than the one programmed in the panel. In this case start the panel according to the instructions in "-CA10 plus Programming Manual", section "Starting the Control Panel".

NOTE: We recommend keypads: CA-10 LED M v1.2 and CA-10 LED S v1.2 or newer to be used, because older keypads LED M and LED S may work incorrect with keypad LCD v3.08 (and next version).

Service mode

After the service mode code, terminated with [#] or [*], is entered, the panel enters the service mode. This is signaled in the keypad by the following message:

Service mode
Menu: ↑↓←→

Press any arrow key to enter multi-level service mode menu which provides easy access to service functions. The functions are grouped by subject. The arrow keys ▲▼ scroll the list of the current level of the menu. The key ► expands the next (lower in hierarchy) menu level. The key ◀ turns back to the previous (higher in hierarchy) level.

For example if Monitoring is selected (pointed by the arrow on the display) then pressing ► twice followed by pressing ◀ twice will result in the following sequence:

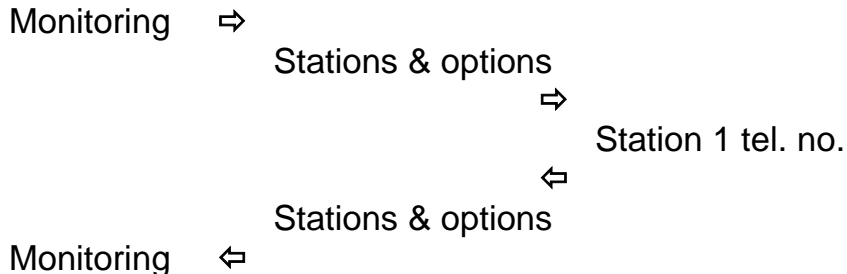

The following pages show the structure of the menu. The functions programming the LCD-L keypad are grouped in a separate menu described later in this guide.

SERVICE MODE MENU

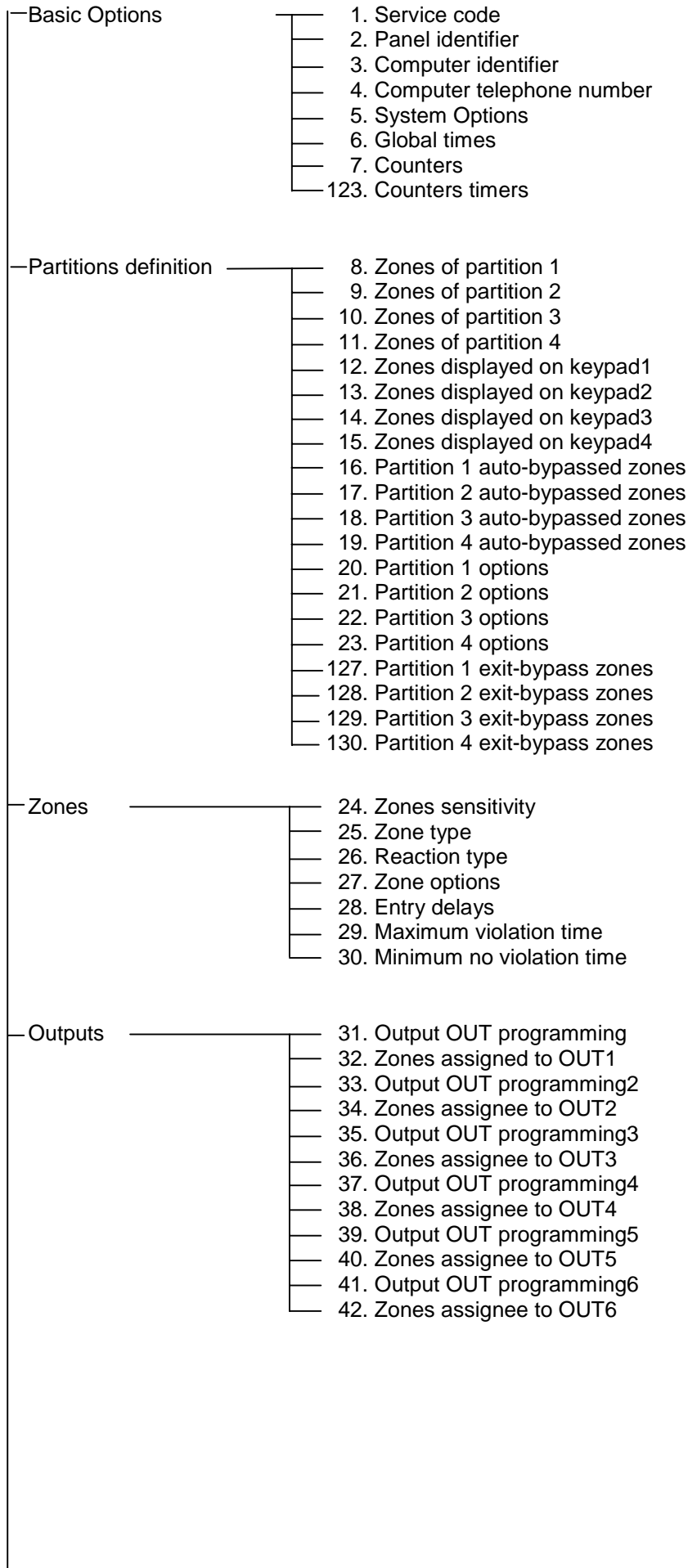

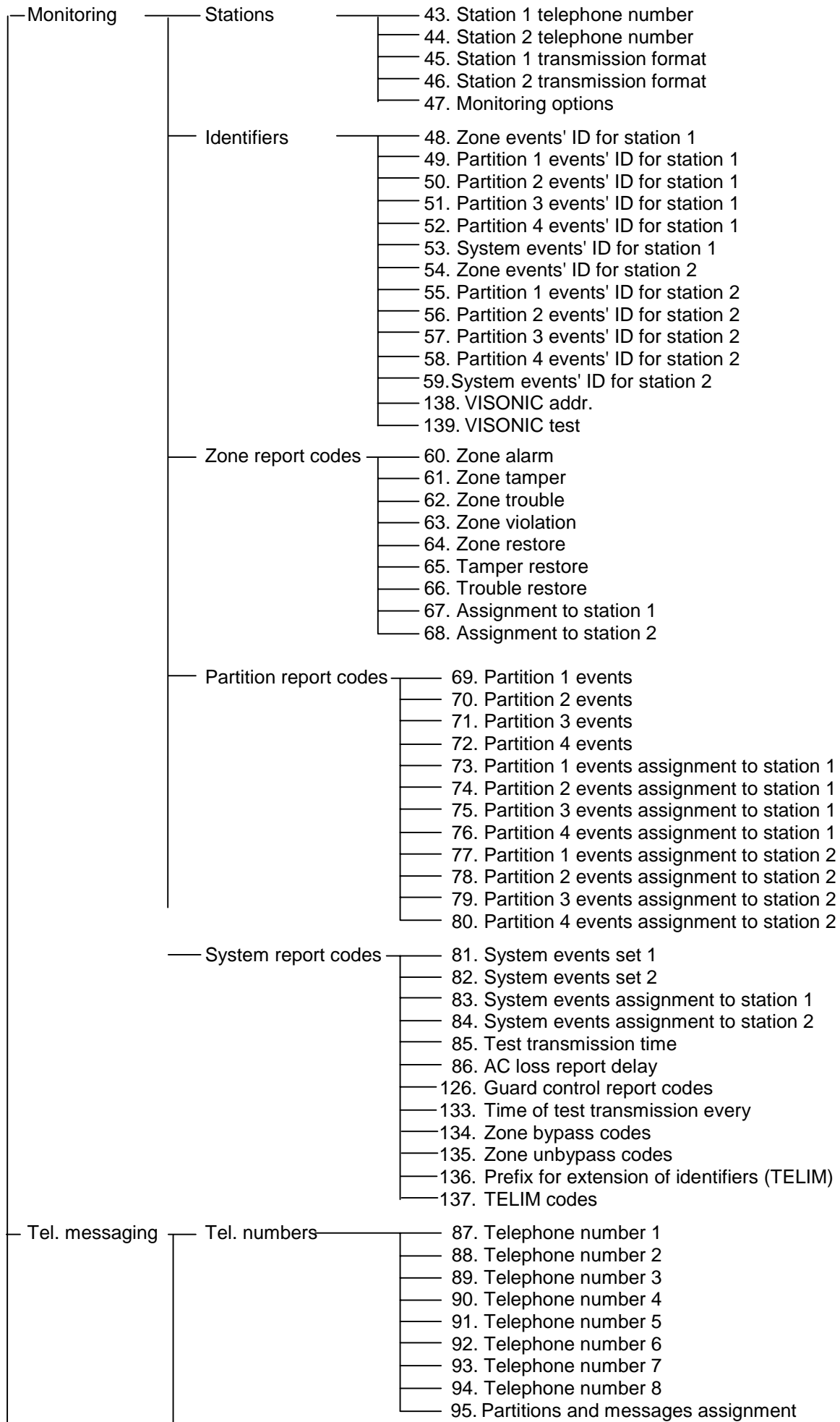

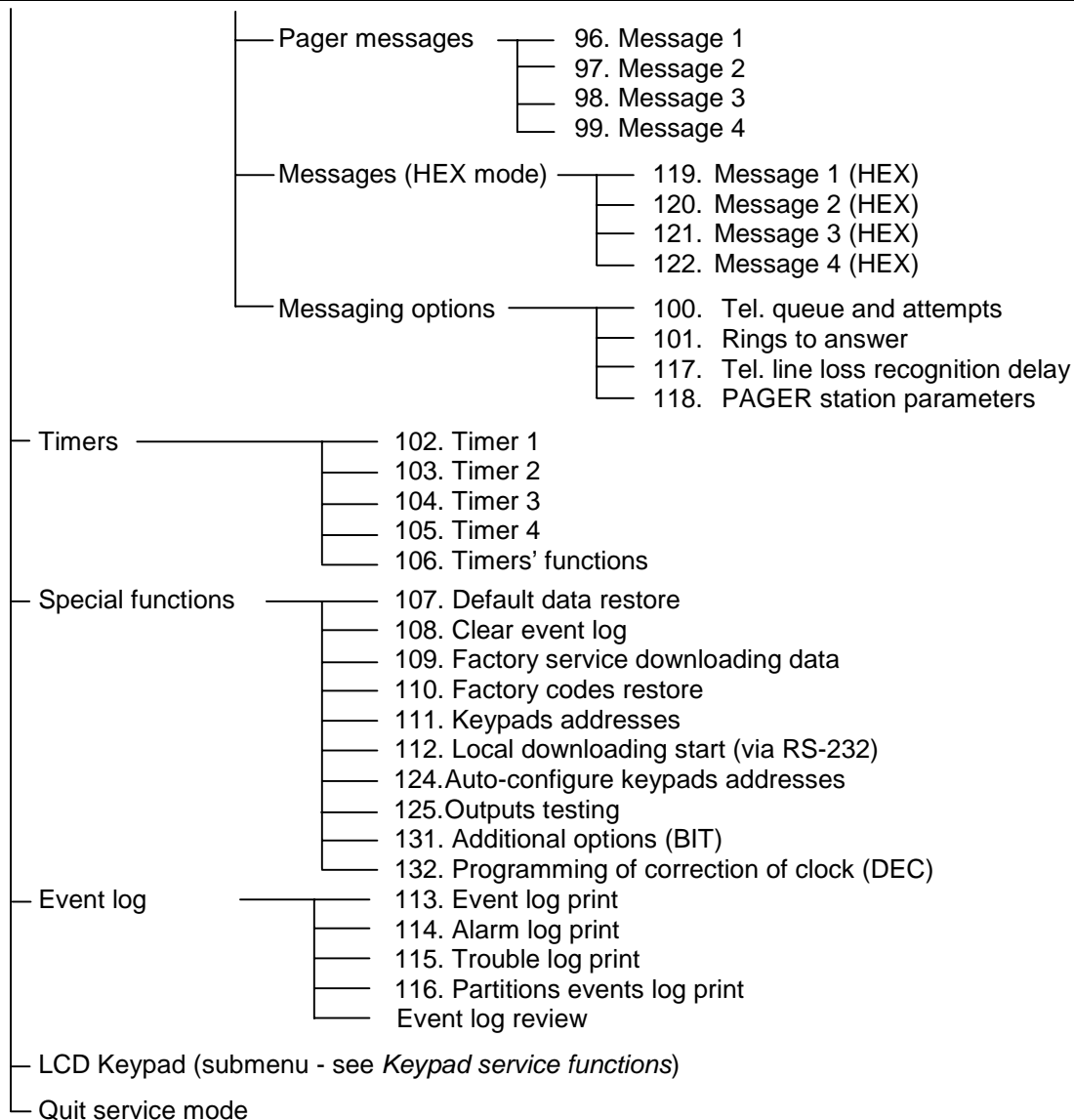

Notes:

- To call a function (currently pointed by the display arrow) press [#] or ►.
- To cancel a function press [*] or ◀ or sometimes the combination of [*] and [#] (this depends on the type of the function - in some functions the keys [*] and ◀ are used to edit data).
- It is possible to call a function straight by entering its number (without using the menu).
- Function FS-124 called from LCD keypad programs keypads addresses and makes additional configuring actions. The system require to call this function from each connected LCD keypad. Do not change manually keypad addresses with function FS-111!

Bit functions

After a bit function is called the keys ◀ ► will change the cursor position and the keys ▲ ▼ will the value of the bit at the cursor position. It is also possible to enter the desired bit number with the numeric keys. Bit numbers 10-16 are entered by pressing [*] followed by the key with the second digit. The combination of [*] and [#] terminates the function.

In this way variables of type "zone list" are programmed (e.g. Programming partition zones).

Bit functions with a list

After a bit function with a list is called in the first line of the display the function name will be shown, while in the second line the first position in the bit switch list is displayed (e.g. System options). The character **■** indicates that the option is on. To change the switch state press any numeric key. The keys **▲▼** will scroll the switch list.

Multiparameter functions

In the case of functions which are used to program several parameters. The keys **▲▼** choose the parameter to be modified, the key **◀** deletes the character which proceeds the cursor and the key **▶** cancel any changes to the currently edited parameter. Parameter values are entered with numeric keys. To enter HEX digits A-F press [*] followed by one of the digits 0-5.

Editing descriptions

During programming of text format messages, the keys **◀▶** control the cursor, [*] toggles the mode (text mode / numeric mode) and [#] confirms the entire text value. The remaining keys function depend on the mode.

Key	Numeric mode function		Text mode function	
▲	delete proceeding character		previous character (in the alphabet)	
▼	toggle insert/overwrite		next character (in the alphabet)	
1	1	1	.	,
abc 2	2	2	A	a
def 3	3	3	D	d
ghi 4	4	4	G	g
jkl 5	5	5	J	j
mno 6	6	6	M	m
pqrs 7	7	7	P	p
tuv 8	8	8	T	t
wxyz 9	9	9	W	w
0	0	0	space	-

The text mode is signaled by * in the upper right corner of the display. Use numeric keys to enter characters according to the table. Lowercase characters are obtained by pressing the corresponding numeric key twice. To cancel programming a description, press sequentially [*] and [#] while in the numeric mode.

Keypad service functions

Keypad service functions are available in the panel service mode through the submenu LCD Keypad at the top level of the Service mode menu. The structure of the submenu follows:

LCD KEYPAD SUBMENU

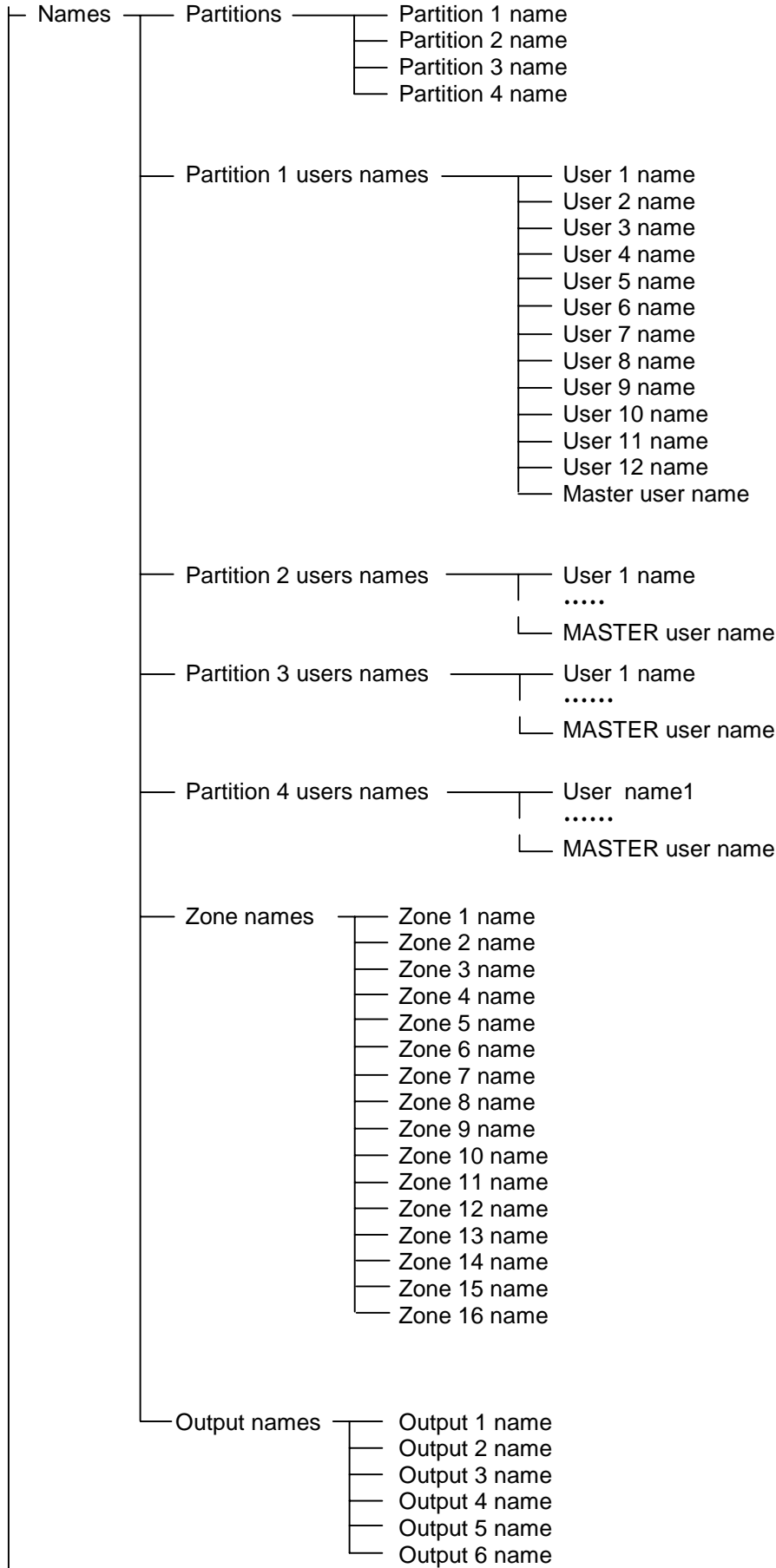

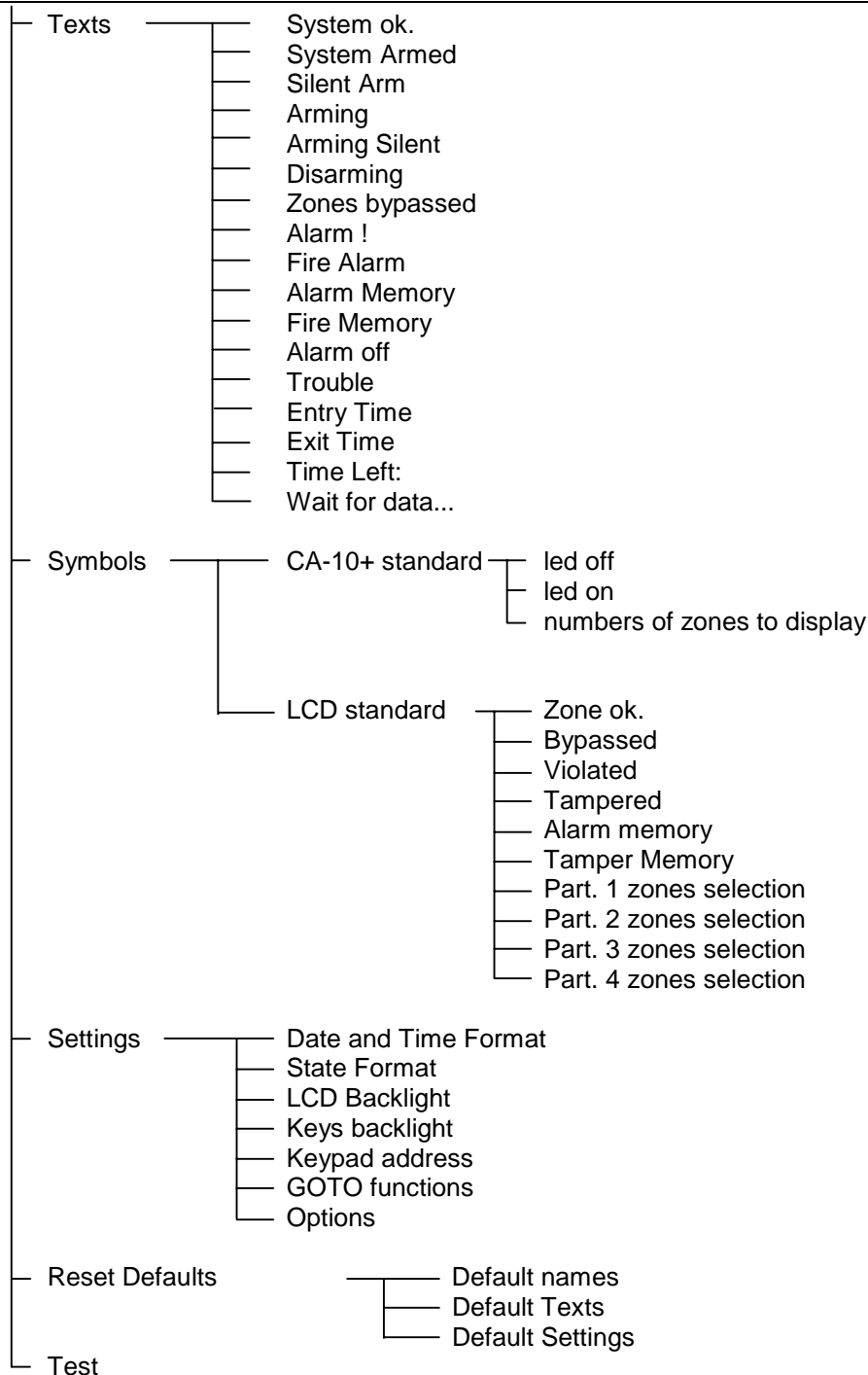

Partition names

The functions are used to program partition descriptions which are displayed when GOTO function is called. The name of the current partition is displayed when the key ▼ is pressed.

Partition users names

User names are used when the system is armed, disarmed or when the event log is reviewed.

Zone names

The names are used when event log is being reviewed, violations and alarms occur and when service functions used to set zone parameters are called.

Output names

The names are used to indicate destination of panel outputs. They are displayed when event log is being reviewed or output functions are being programmed (in the service mode).

Texts

Standard system messages (like "alarm", "armed" etc.) can be modified with this function according to user preferences and requirements of a specific installation.

CA10 plus LED standard characters

In zone monitoring mode, according to LED standard, the character * corresponds to LED control on and □ corresponds to LED off. It is possible to change these characters some other. The parameter "number of zones to be displayed" is used to limit the number of monitored zones in the case when some are not used (c.f. service functions 12..15, control panel user manual). This can be necessary after switching to another partition with GOTO function.

LCD standard characters

Characters which signal various zone states in zone monitoring mode, LCD standard, can be modified here. The {choice of zones} option can be used to eliminate non existing zones.

Note: *The choice of zones is used to select zones which are to be displayed as violated or alarming zones by corresponding panel functions. This is primarily used in text mode to limit the displayed names of zones to the set of zones of the current partition (to which the keypad is currently attached).*

Time format

Display back-light

Keypad back-light

The above functions to choose the format of date and time to be displayed in the first line of the display and the back-light status of the display and the keypad. Symbols to be used: 0 - back-light off, 1/2 - weak back-light, 1 - full back-light, auto - back-light is turned on after a key is pressed and then turned off after time set with use of option "Long illumination" (40 or 150 seconds).

Status format

The function selects the panel's operation mode:

- text mode ("descriptions"): system status is communicated by means of textual messages,
- zones according to CA10 plus mode: status of maximum of 12 zones is displayed according to the list programmed with panel service functions FS12-FS15,
- zones according to LCD mode: status of maximum of 16 selected zones is displayed, indicating violations, alarms, tamper conditions, alarm log etc.

GOTO function

GOTO function performed on LCD-L keypad is easier than on LED one. LCD-L keypad allows zone switching without returning to the base zone (the key [*]). This menu selects partitions to which switching with GOTO is allowed.

Notes:

- *After programming GOTO function it is necessary to perform an automatic configuration of attached keypads addresses with the service function FS124. The detected addresses should not be changed with the FS111 function.*
- *In the case of installation with an LCD-L keypad, expanders adapted to LCD keypads should be used (software version 2, manufactured since February 1998). Older expander versions will also operate with LCD-L keypads, but will not support multipartition systems.*

Options

The functions enables setting some additional parameters, such as:

- display exit delay time left,
- exit delay sound signaling type,
- beep on key pressed,
- change back-lighting on key pressed,
- how long to wait for pressing next key (40s / 150s),
- is illumination of keypad and display to be permanent,
- are functions assigned to arrow keys to be active.

{Status priority} parameter determines the way system status is displayed in the text mode. If it is off all relevant messages are displayed one after another in a closed cycle. If it is on only the highest priority message is displayed. The following priority levels are assigned by default (starting with the highest):

1. entry delay,
2. fire alarm,
3. burglary alarm,
4. armed (or silent armed)
5. fire alarm occurred,
6. burglary alarm occurred,
7. exit delay.

Reset Defaults

The function restores default parameters of keypad.

Test

The function enables keypad functioning correctness to be tested. Starting this function restores default keypad parameters. To preserve your own parameters it is necessary to write them into computer before testing, and after testing they should be again programmed from the computer. Pressing key [*] after end of testing will restart keypad.

Computer supported programming

All keypad parameters (v3.00) can be programmed from the computer by means of the **DLOAD10** program (version 1.00.03 and later) working in the WINDOWS environment. The program serves also the previous versions of LCD keypads. Use the cable for panel programming to connect the keypad to the computer RS-232 port. No initialization is required - the keypad will automatically respond to DLOAD10 commands.

Specifications

Minimum power supply voltage	11 V
Maximum power supply voltage	16 V
Maximum current.....	170 mA
Current drawn	
logic circuits	30 mA
keypad back-lighting	20 mA
LED controls on (all: ALARM, TROUBLE, ARMED)	20 mA
display back-lighting 1/2 (weak)	35 mA
display full back-lighting	100 mA
Dimensions	145x114x29 mm

HISTORY OF THE MANUAL UPDATES

The updates below refer to the manual for the LCD Keypad with software version **3.00**.

Date	Program version	Description of updates
	3.01-3.06	<i>No changes.</i>
01-2003	3.07 3.08	<ul style="list-style-type: none"> • Service function menu updated – FS 133 added to “system codes” (p. 7).
07-2003	3.10	<ul style="list-style-type: none"> • The service functions menu has been enhanced by new functions: FS 125 (p. 8), FS 134-139 (p. 7). • New option that applies to possibility of activation the functions assigned to arrow keys has been added (p. 13). • The description of keypad service function: “Reset Defaults” has been added (p. 13). • New keypad service function: “Test” has been added (p. 13).