

# Integra

sample system configuration

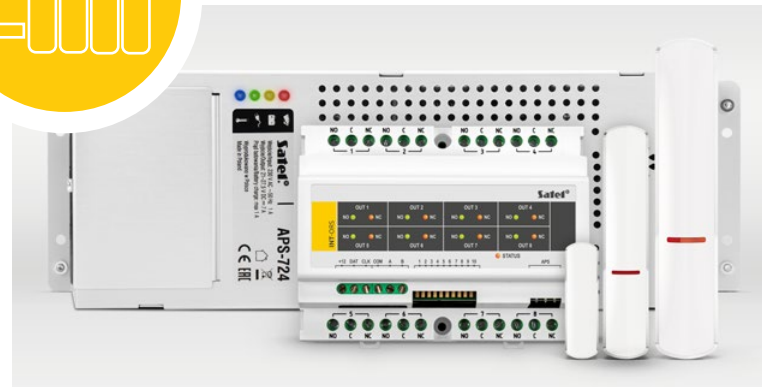
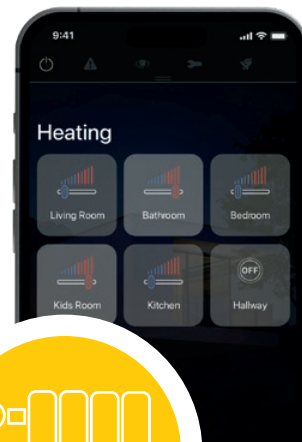

## Heating System Control

To make your system more affordable and comfortable, you can use it to control both security and building automation. Using the same system components for security and building automation makes the whole installation more cost-effective.

## Heating System Control

You can employ the **INTEGRA** or **INTEGRA Plus** intruder alarm system for heating control, among many other functions, thus reducing the overall energy costs while maintaining the same level of comfort. Electronically controlled radiator thermostats can be implemented into building automation scenarios. These can be run automatically (at a specified time) or directly in their **INTEGRA CONTROL** mobile app or on the touchscreen keypad (either an **INT-TSH2**, **INT-TSG2**, or **INT-TSI**). For example, the system can maintain a higher or lower temperature in a room according to a schedule. The system can also consider other parameters and data, for example, whether users are home, or windows are open.

### Guidelines:

- Living room and bathroom radiators work in the "day/night" cycle. During the day, the system maintains a higher temperature. During the night, the radiators switch to the eco-mode, lowering the temperature by a few degrees.
- When no one is home, and the system is armed, the control panel unit maintains a lower temperature regardless of the time of day.
- To reduce home heat loss, the system turns off the radiators in rooms with open windows. Additionally, when users try to arm the system, they're immediately informed about the windows left open.
- Indoor and outdoor temperatures are displayed on the keypads connected to the control panel or in the mobile app that controls the alarm system.
- You can program the default temperatures for the day and night modes, as well as the timers for automation control on the keypad or in the mobile app.

### Example configuration:

- The alarm system is controlled by the **INTEGRA 128 Plus** control panel unit that additionally controls building automation.
- The **APD-200** wireless motion detector installed in the living room, alongside the **AXD-200** universal detector with the flood detector mode enabled in the bathroom, transmit the current temperatures to the control panel. Both detectors feature a built-in temperature sensor.
- The **ADD-200** wireless detector measures the current outdoor temperature.
- The windows in the living room and bathroom are monitored by the **B-2** magnetic contact.
- The wireless detectors are supervised by the **ACU-280** controller of the **ABAX 2** wireless system.
- Heating is controlled by the drives of heater thermostats, which in turn are controlled by the **INT-ORS** expansion module. An alternative to this solution would be to use the **ART-200** wireless radiator thermostats.
- The dedicated "thermostat" type outputs are used to control the operation of radiator valves. Temperature settings can be changed conveniently using the **INTEGRA CONTROL** mobile app and the **INT-TSH2**, **INT-TSG2** and **INT-TSI** touchscreen keypads.
- Valve drives run on 24 V DC supplied by the **APS-724** backup power supply.
- The backup power supply is connected to a backup battery which powers the system in case of an outage.



### INTEGRA CONTROL

- control of **INTEGRA/INTEGRA Plus** intruder alarm and building automation system
- secure and encrypted communication with control panel unit
- access to live camera feed
- supports MACRO commands
- Push notifications

### Zone configuration

No.	Zone name	Part.	Wiring type	Sensitivity	Zone type	Entry delay	Max.Viol. Time	Max.No Viol.Time
1	Living RM Window	1	1: NC	320 ms.	5: Instant	0 sec.	0 sec.	0 h.
2	Bathroom Window	1	1: NC	320 ms.	5: Instant	0 sec.	0 sec.	0 h.
17	Living RM Movemnt	1	4: 2EOL/NC	320 ms.	5: Instant	0 sec.	0 sec.	0 h.
18	Bathroom Flood	1	4: 2EOL/NC	320 ms.	52: 24h Water leakage	0 sec.	0 sec.	0 h.
19	Outdoor Temp	1	4: 2EOL/NC	320 ms.	47: No alarm action	0 sec.	0 sec.	0 h.

### Output configuration

No.	Output name	Output funct.	Cut off time	State indication	Pol+	Pulse/Latch	Triggering:	Triggering LCD keypad	Triggering Part./Part. keypad	Alarm clearing in part
17	Living RM Radiat	46: Outputs logical AND	0 min, 30 sec	0 standard	X		outputs: 125,127			
18	Bathroom Radiat	46: Outputs logical AND	0 min, 30 sec	0 standard	X		outputs: 126,128			
124	Arming status	22: Full Armed status	0 min, 30 sec	0 standard	X				1+32	
125	Living RM Window	17: READY status	0 min, 30 sec	0 standard	X		zones: 1			
126	Bathroom Window	17: READY status	0 min, 30 sec	0 standard	X		zones: 2			
127	Living RM Thermo	120: Thermostat	0 min, 30 sec	0 standard	X		zones: 17			1
128	Bathroom Thermo	120: Thermostat	0 min, 30 sec	0 standard	X		zones: 18			2

**Triggering output 127**

Temperature detector

1	2	3	4	5	6	7	8
9	10	11	12	13	14	15	16
17	18	19	20	21	22	23	24
25	26	27	28	29	30	31	32
33	34	35	36	37	38	39	40
41	42	43	44	45	46	47	48
49	50	51	52	53	54	55	56
57	58	59	60	61	62	63	64
65	66	67	68	69	70	71	72
73	74	75	76	77	78	79	80
81	82	83	84	85	86	87	88
89	90	91	92	93	94	95	96
97	98	99	100	101	102	103	104
105	106	107	108	109	110	111	112
113	114	115	116	117	118	119	120
121	122	123	124	125	126	127	128

Temperature T1: 19.0 °C  
Temperature T2: 22.0 °C  
Hysteresis: 0.5 °C

Output forcing T1: 124

Timers controlling T1/T2:

1	2	3	4	5	6	7	8
9	10	11	12	13	14	15	16
17	18	19	20	21	22	23	24
25	26	27	28	29	30	31	32

Timers set

**Triggering output 128**

Temperature detector

1	2	3	4	5	6	7	8
9	10	11	12	13	14	15	16
17	18	19	20	21	22	23	24
25	26	27	28	29	30	31	32
33	34	35	36	37	38	39	40
41	42	43	44	45	46	47	48
49	50	51	52	53	54	55	56
57	58	59	60	61	62	63	64
65	66	67	68	69	70	71	72
73	74	75	76	77	78	79	80
81	82	83	84	85	86	87	88
89	90	91	92	93	94	95	96
97	98	99	100	101	102	103	104
105	106	107	108	109	110	111	112
113	114	115	116	117	118	119	120
121	122	123	124	125	126	127	128

Temperature T1: 21.0 °C  
Temperature T2: 24.0 °C  
Hysteresis: 0.5 °C

Output forcing T1: 124

Timers controlling T1/T2:

1	2	3	4	5	6	7	8
9	10	11	12	13	14	15	16
17	18	19	20	21	22	23	24
25	26	27	28	29	30	31	32

Timers set

### Configuration of the ABAX 2 wireless system controller

No.	Name	Type	Device type	Serial num.	ARL	Always	Configuration	Filter	Temp. cor.	ECO
1	Z-17	Living RM Movemnt	Instant (with TAMPER)	APD-200 (PIR)	0000719		2: medium Sensitivity	33	0.0°C	
2	Z-18	Bathroom Flood	24h Water leakage (with TAMPER)	AFD-200 (Flood Detector)	0000801			33	0.0°C	
3	Z-19	Outdoor Temp	No alarm action (with TAMPER)	ADD-200 (dusk sensor)	0001766		2: Sensitivity 2	33	0.0°C	

### Timer configuration

No.	Name	User edits	Monday	Tuesday	Wednesday	Thursday	Friday	Saturday	Sunday	Everyday
1	Timer Living RM	X	On	Off	On	Off	On	Off	On	Off
2	Timer Bathroom	X	6:00	21:00	6:00	22:30	7:00	22:00	7:00	23:00

Connection diagram on the next page →

# Connection diagram

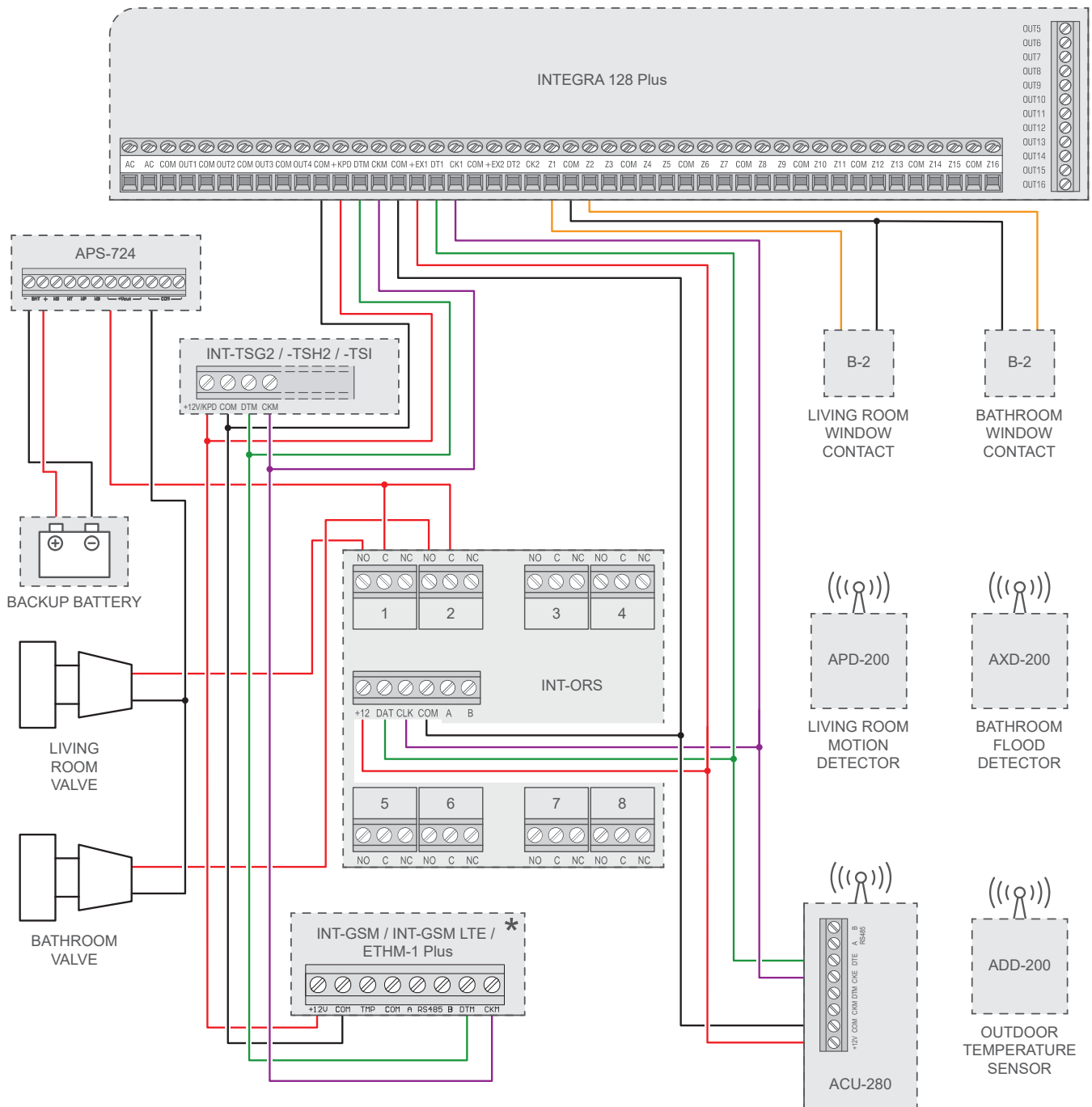

\* Allows controlling system with the INTEGRA CONTROL mobile app  
 This diagram is for demonstration purposes only, and includes only selected devices from the system.



U-JTJZ-OGREZEWANIE-EN0723

**Satel**  
 MADE TO PROTECT

Budowlanych 66 Str.  
 80-298 Gdansk, Poland  
 phone +48 58 320 94 00  
 fax +48 58 320 94 01  
 e-mail: trade@satel.pl

www.satel.pl

## INSTALLER KNOWLEDGE BASE

Register at  
[support.satel.pl](http://support.satel.pl)

- webinars
- technical support
- manuals

